

» DYNACODE IP SERIES

- Splash-proof electronics and print mechanics
- Separate transfer ribbon cassette and cleaning cassette
- Maximum protection in harsh production conditions
- Electronic control unit is wall-mountable
- Connection for 24V industrial encoder
- Cable outlet at rear and on side
- Audible signal issued in case of fault
- Large graphical display (of benefit for displaying international character sets and special symbols) with 132 x 64 pixel resolution and white backlighting
- 2 x USB host for connecting a USB keyboard and a thumb drive



» Water and dust protection equipment

After all the necessary connections have been established to the control unit and all unused connectors have been covered using the appropriate accessory, the control unit is protected against water and dust at all times, in accordance with protection class IP65.

Owing to conditions during the operation of direct printing units of this type, the printing mechanism cannot be fully protected against the ingress of water while printing is in progress.

However, using the special cleaning cassette, it is possible to protect the printing mechanism during downtimes against the ingress of water and dust in accordance with protection class IP65.

The splash-proof version of the Dynacode offers additional protection in harsh production environments. The optionally available version additionally dispenses with bulky and bothersome covers to protect the device, as neither print module nor control unit must be dismantled or covered during the cleaning process. This means that production downtimes are even further reduced.

The cleaning cassette necessary for this can simply replace the ribbon cassette within seconds. The splash-proof Dynacode version is ideally suited for marking hygienic products and for printing in production environments where wet cleaning is required, such as in dairies or coffee roasting plants.



» External inputs and outputs

The machines of the Dynacode IP series are equipped with six outputs for machine communication, which are electrically isolated by an optocoupler. Alternatively an output can be switched via an internal relay (230V/1A). The Dynacode IP is also provided with a clock input (print start) for connection of a product sensor (5-24V).



» Installation positions

The Dynacode IP is a direct print unit which was designed to be integrated into existing labelling and packaging systems. The Dynacode IP prints flawlessly in any installation position and was specially developed for continuous printing.



» Interfaces

The Dynacode IP comes as standard with a serial, USB and Ethernet interface. In addition, the Dynacode IP has an USB host, to enable the connection of an external USB keyboard and/or an USB thumb drive. The Dynacode IP automatically detects which interface the control signals are coming from.

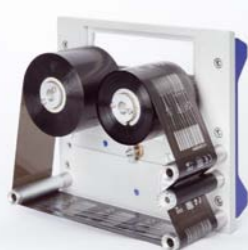

» Transfer ribbon cassette

Thanks to its sophisticated design, the transfer ribbon cassette can be replaced in only a few seconds. Both externally-wound and internally-wound transfer ribbons can be used in the transfer ribbon cassette.



» Cleaning cassette

The specially developed cleaning cassette offers maximum protection in harsh production conditions. Using the cleaning cassette avoids the time-consuming and labour-intensive covering of machines in production environments which require wet cleaning.

» TECHNICAL DATA

» DYNACODE IP SERIES

| DYNACODE IP 53 | |
|-------------------------------|--|
| PRINT | |
| Max. Print Width | 53.3 mm |
| Max. Print Length | Continuous Mode 6000 mm Intermittent Mode 75 mm |
| Frame Passage Width | customized |
| Resolution | 300 dpi |
| Print Speed | Continuous Mode 50 – 800 mm/s Intermittent Mode 50 – 600 mm/s |
| Max. Back Speed | 600 mm/s (intermittent mode only) |
| Printhead | Corner Type |
| DIMENSIONS | |
| Print Mechanics | |
| Without Mounting Frame | 204 mm x 182 mm x 235 mm |
| With Mounting Frame | depending on passage width |
| Control Unit | 310 mm x 165 mm x 350 mm |
| Connecting Cable to Mechanics | 2.5 m |
| WEIGHT | |
| Print Mechanics | 9.5 kg |
| Electronics with Cable | 8 kg |
| FONTS | |
| Font Types | 6 Bitmap fonts, 6 Vector fonts/TrueType fonts, 6 proportional fonts other fonts on demand |
| BAR CODES | |
| 1D Bar Codes | CODABAR, Code 128A, Code 128B, Code 2/5 interleaved, Code 39, Code 39 extended, Code 93, EAN 13, EAN 8, EAN ADD ON, GS1-128, Identcode (German Post Code), ITF 14, Leitcode (German Post Code), Pharmacode, PZN Code, UPC-A, UPC-E |
| 2D Bar Codes | CODABLOCK F, DataMatrix, GS1 DataMatrix, MAXICODE, PDF417, QR Code |
| Composite Bar Codes | GS1 DataBar Expanded, GS1 DataBar Limited, GS1 DataBar, Omnidirectional, GS1 DataBar Stacked, GS1 DataBar Stacked, Omnidirectional, GS1 DataBar Truncated |
| ACOUSTIC EMISSION | |
| Average Sound Power Level | 60 dB(A) |
| ELECTRONICS | |
| Processor | High Speed 32 Bit |
| RAM | 16 MB / 64 MB (on demand) |
| Slot | for Compact Flash card type I (inside the control unit) |
| Max. Storage | 16 MB |
| Battery Cache | for real-time clock (storage of data with shut-down) |
| Warning Signal | acoustic signal when error |
| INTERFACES | |
| Serial | RS-232C (max. 115,200 baud) |
| Ethernet | 10/100 Base T, LPD, RawIP-Printing, DHCP, HTTP, FTP |
| 2 x USB Master | connection for external USB keyboard and memory stick |
| TRANSFER BAND | |
| Coating | outside / inside * |
| Max. Roll Diameter | 98 mm |
| Core Diameter | 25.4 mm / 1" |
| Max. Length | 900 m |
| CONNECTION VALUES | |
| Pneumatic Connection | min. 6 bar dry and free from oil |
| Nominal Voltage | 110 V – 230 V / 50 – 60 Hz |
| Nominal Current | 230 V / 1.5 A – 110 V / 3 A |
| OPERATING CONDITIONS | |
| Ingress Protection Rating | IP65 |
| Temperature | 5 – 40 °C |
| Max. Relative Humidity | 80 % (non condensing) |

* optional

Technical data subject to change

» PRINT MECHANICS VERSIONS

» Dynacode IP print mechanics right hand version, intermittent mode

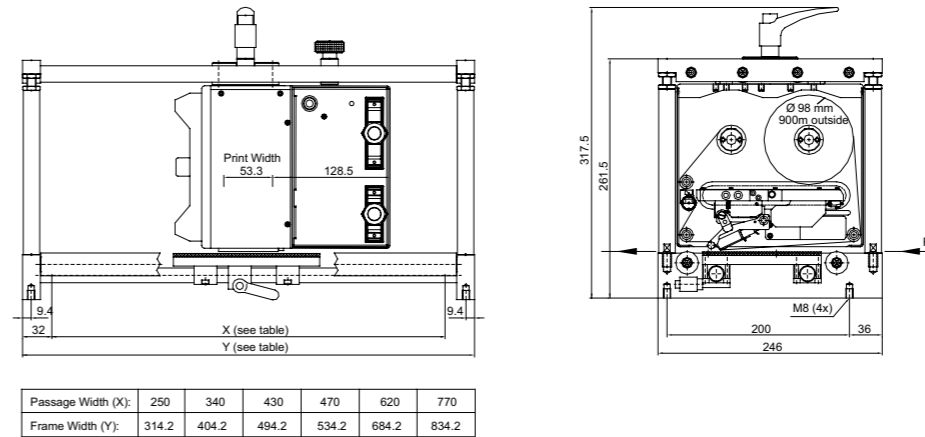

» Dynacode IP print mechanics right hand version, continuous mode

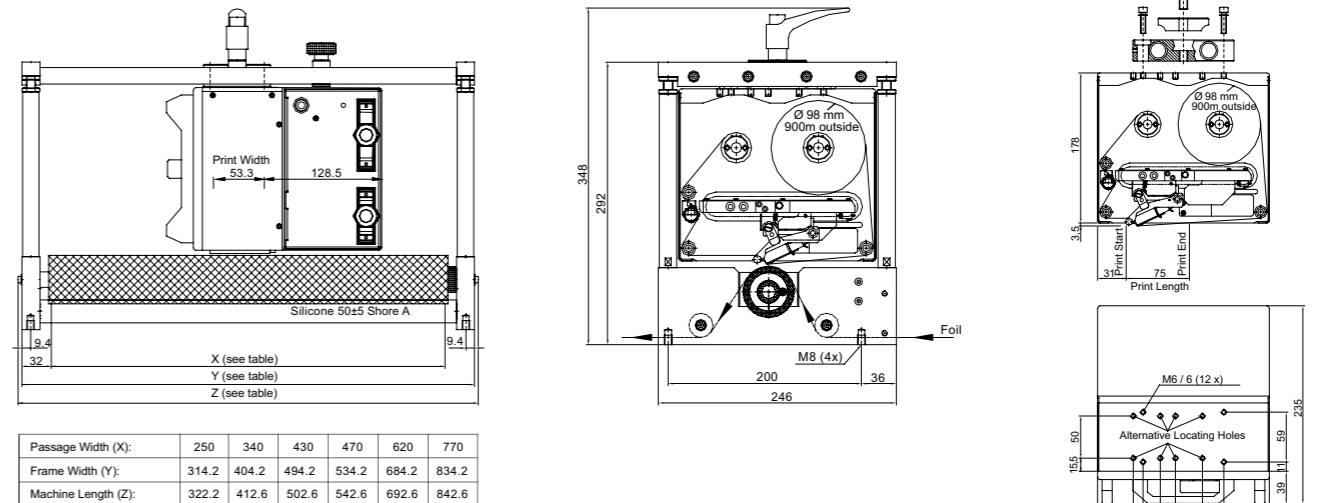

» Dynacode IP control unit

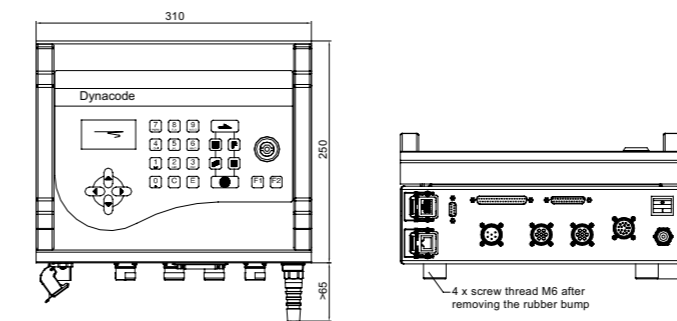

Martek Industries Ltd
12b Ridings Park Industrial Estate
Eastern Way
Cannock
Staffs - WS11 7FJ

Tel: 01543 502202
Fax: 01543 467726
Email: sales@martekonline.co.uk
www.martekonline.co.uk